

1325



# Table of Contents

1	Introduction and Safety.....	3
1.1	Introduction.....	3
1.2	Safety terminology and symbols.....	3
1.3	User safety.....	3
1.4	Ex-approved products.....	3
1.5	Special hazards.....	4
1.5.1	Biological hazards.....	4
1.5.2	Wash the skin and eyes.....	4
1.6	Protecting the environment.....	4
1.7	End of life product disposal.....	4
1.8	Spare parts.....	4
1.9	Warranty.....	4
2	Transportation and Storage.....	4
2.1	Examine the delivery.....	4
2.1.1	Examine the package.....	4
2.1.2	Examine the unit.....	4
2.2	Transportation guidelines.....	5
2.2.1	Precautions.....	5
2.2.2	Lifting.....	5
2.3	Temperature ranges for transportation, handling and storage.....	5
2.4	Storage guidelines.....	5
3	Product Description.....	5
3.1	Products included.....	6
3.2	Pump design.....	6
3.3	Monitoring Equipment.....	6
3.4	The data plate.....	6
3.5	Approvals.....	7
3.6	Product denomination.....	7
4	Installation.....	7
4.1	Precautions.....	7
4.1.1	Hazardous atmospheres.....	8
4.1.2	Install with Wet well installation.....	8
4.1.3	Install with Free-standing installation.....	9
4.2	Make the electrical connections.....	9
4.2.1	General precautions.....	9
4.2.2	Grounding (earthing).....	10
4.2.3	Prepare the SUBCAB™ cables.....	10
4.2.4	Connect the motor cable to the pump.....	10
4.2.5	Connect the motor cable to the starter and monitoring equipment.....	11
4.2.6	Cable charts.....	11
4.3	Check the impeller rotation.....	13
5	Operation.....	13
5.1	Precautions.....	13
5.2	Start the pump.....	14
6	Maintenance.....	14
6.1	Precautions.....	14
6.2	Change the coolant.....	14
6.2.1	Empty the coolant.....	14
6.2.2	Fill with coolant.....	15
6.3	Service the pump.....	15
6.3.1	Inspection.....	15
6.3.2	Overhaul.....	16
6.3.3	Service in case of alarm.....	16
6.4	Replace the impeller.....	16
6.4.1	Remove the impeller.....	16
6.4.2	Install the impeller.....	17
7	Troubleshooting.....	18
7.1	Electrical troubleshooting.....	18
7.2	The pump does not start.....	18
7.3	The pump does not stop when a level sensor is used.....	19
7.4	The pump starts-stops-starts in rapid sequence.....	19
7.5	The pump runs but the motor protection trips.....	19
7.6	The pump delivers too little or no water.....	20

8 Technical Reference.....	20
8.1 Motor data.....	20

# 1 Introduction and Safety



## 1.1 Introduction

### Purpose of the manual

The purpose of this manual is to provide the necessary information for working with the unit. Read this manual carefully before starting work.

### Read and keep the manual

Save this manual for future reference, and keep it readily available at the location of the unit.

### Intended use





#### WARNING:

Operating, installing, or maintaining the unit in any way that is not covered in this manual could cause death, serious personal injury, or damage to the equipment and the surroundings. This includes any modification to the equipment or use of parts not provided by Xylem. If there is a question regarding the intended use of the equipment, please contact a Xylem representative before proceeding.

### Other manuals

See also the safety requirements and information in the original manufacturer's manuals for any other equipment furnished separately for use in this system.

### Description of user and installer symbols

	Specific information for personnel in charge of installing the product in the system (plumbing and/or electrical aspects) or in charge of maintenance.
	Specific information for users of the product.

## 1.2 Safety terminology and symbols



### About safety messages

It is extremely important that you read, understand, and follow the safety messages and regulations carefully before handling the product.

They are published to help prevent these hazards:



- Personal accidents and health problems
- Damage to the product and its surroundings
- Product malfunction

### Hazard levels

Hazard level	Indication
 <b>DANGER:</b>	A hazardous situation which, if not avoided, will result in death or serious injury
 <b>WARNING:</b>	A hazardous situation which, if not avoided, could result in death or serious injury
 <b>CAUTION:</b>	A hazardous situation which, if not avoided, could result in minor or moderate injury
<b>NOTICE:</b>	Notices are used when there is a risk of equipment damage or decreased performance, but not personal injury.

### Special symbols

Some hazard categories have specific symbols, as shown in the following table.

Electrical hazard	Magnetic fields hazard
 <b>Electrical Hazard:</b>	 <b>CAUTION:</b>

## 1.3 User safety

All regulations, codes, and health and safety directives must be observed.

### The site

- Observe lockout/tagout procedures before starting work on the product, such as transportation, installation, maintenance, or service.
- Pay attention to the risks presented by gas and vapors in the work area.
- Always be aware of the area surrounding the equipment, and any hazards posed by the site or nearby equipment.

### Qualified personnel

This product must be installed, operated, and maintained by qualified personnel only.

### Protective equipment and safety devices

- Use personal protective equipment as needed. Examples of personal protective equipment include, but are not limited to, hard hats, safety goggles, protective gloves and shoes, and breathing equipment.
- Make sure that all safety features on the product are functioning and in use at all times when the unit is being operated.

## 1.4 Ex-approved products

Follow these special handling instructions if you have an Ex-approved unit.

### Personnel requirements

These are the personnel requirements for Ex-approved products in potentially explosive atmospheres:

- All work on the product must be carried out by certified electricians and Xylem authorized mechanics. Special rules apply to installations in explosive atmospheres.
- All users must know about the risks of electric current and the chemical and physical characteristics of the gas, the vapor, or both present in hazardous areas.
- Any maintenance for Ex-approved products must conform to international and national standards (for example, IEC/EN 60079-17).

Xylem disclaims all responsibility for work done by untrained and unauthorized personnel.

### Product and product handling requirements

These are the product and product handling requirements for Ex-approved products in potentially explosive atmospheres:

- Only use the product in accordance with the approved motor data.
- You must fully submerge the Ex-approved product during normal operation. Dry running during service and inspection is only permitted outside the classified area.
- Before you start work on the product, make sure that the product and the control panel are isolated from the power supply and the control circuit, so they cannot be energized.
- Do not open the product while it is energized or in an explosive gas atmosphere.
- Intrinsically safe circuits are normally required for the automatic level-control system by the level regulator if mounted in zone 0.
- The yield stress of fasteners must be in accordance with the approval drawing and the product specification.
- Do not modify the equipment without approval from an Ex-approved Xylem representative.
- Only use original Xylem spare parts that are provided by an Ex-approved Xylem representative.
- The thermal contacts that are fitted to the stator windings must be connected correctly to a separate motor control circuit and in use. The thermal contacts shall be connected to a monitoring device, which disconnects the power supply immediately upon activation.

This action prevents the rise of temperatures above the temperature value for the approval classification.

- The width of flameproof joints is more than the values specified in the tables of the IEC 60079-1 standard.
- The gap of flameproof joints is less than the values specified in Table 1 of the IEC 60079-1 standard.
- It is NOT allowed to repair the flameproof joints.

**Guidelines for compliance**

Compliance is fulfilled only when you operate the unit within its intended use. Do not change the conditions of the service without the approval of an Ex-approved Xylem representative. When you install or maintain explosion proof products, always comply with the directive and applicable standards (for example, IEC/EN 60079-14).

**Minimum permitted liquid level**

See the dimensional drawings of the product for the minimum permitted liquid level according to the approval for explosion proof products. If the information is missing on the dimensional drawing, the product must be fully submerged. Level-sensing equipment must be installed if the product can be operated at less than the minimum submersion depth.

**Monitoring equipment**

For additional safety, use condition-monitoring devices. Examples of condition-monitoring devices include, but are not limited to, the following:

- Level indicators
- Temperature detectors in addition to the stator thermal detectors

Any thermal detectors or thermal protection devices delivered with the pump must be installed and in use at all times.

**1.5 Special hazards**

**1.5.1 Biological hazards**

The product is designed for use in liquids that can be hazardous to your health. Observe these rules when you work with the product:

- Make sure that all personnel who may come into contact with biological hazards are vaccinated against diseases to which they may be exposed.
- Observe strict personal cleanliness.



**WARNING: Biological Hazard**

Infection risk. Rinse the unit thoroughly with clean water before working on it.

**1.5.2 Wash the skin and eyes**

Follow these procedures for chemicals or hazardous fluids that have come into contact with your eyes or your skin:

Condition	Action
Chemicals or hazardous fluids in eyes	<ol style="list-style-type: none"> <li>1. Hold your eyelids apart forcibly with your fingers.</li> <li>2. Rinse the eyes with eyewash or running water for at least 15 minutes.</li> <li>3. Seek medical attention.</li> </ol>
Chemicals or hazardous fluids on skin	<ol style="list-style-type: none"> <li>1. Remove contaminated clothing.</li> <li>2. Wash the skin with soap and water for at least 1 minute.</li> <li>3. Seek medical attention, if necessary.</li> </ol>

**1.6 Protecting the environment**

**Emissions and waste disposal**

Observe the local regulations and codes regarding:

- Reporting of emissions to the appropriate authorities
- Sorting, recycling and disposal of solid or liquid waste
- Clean-up of spills

**Exceptional sites**



**CAUTION: Radiation Hazard**

Do NOT send the product to Xylem if it has been exposed to nuclear radiation, unless Xylem has been informed and appropriate actions have been agreed upon.

**1.7 End of life product disposal**

Handle and dispose of all waste in compliance with local laws and regulations.

**EU only: Correct disposal of this product — WEEE Directive on waste electrical and electronic equipment**

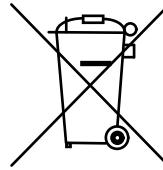

W500972A

This marking on the product, accessories or literature indicates that the product should not be disposed of with other waste at the end of its working life.

To prevent possible harm to the environment or human health from uncontrolled waste disposal, please separate these items from other types of waste and recycle them responsibly to promote the sustainable reuse of material resources.

Waste from electrical and electronic equipment can be returned to the producer or distributor.

**1.8 Spare parts**



**CAUTION:**

Only use the manufacturer's original spare parts to replace any worn or faulty components. The use of unsuitable spare parts may cause malfunctions, damage, and injuries as well as void the warranty.

**1.9 Warranty**

For information about warranty, see the sales contract.

**2 Transportation and Storage**



**2.1 Examine the delivery**

**2.1.1 Examine the package**

1. Examine the package for damaged or missing items upon delivery.
2. Record any damaged or missing items on the receipt and freight bill.
3. If anything is out of order, then file a claim with the shipping company.

If the product has been picked up at a distributor, make a claim directly to the distributor.

**2.1.2 Examine the unit**

1. Remove packing materials from the product.
  - Dispose of all packing materials in accordance with local regulations.
2. To determine whether any parts have been damaged or are missing, examine the product.
3. If applicable, unfasten the product by removing any screws, bolts, or straps.
  - Use care around nails and straps.
4. If there is any issue, then contact a sales representative.

## 2.2 Transportation guidelines

### 2.2.1 Precautions



#### **DANGER: Crush Hazard**

Moving parts can entangle or crush. Always disconnect and lock out power before servicing to prevent unexpected start-up. Failure to do so could result in death or serious injury.



#### **Position and fastening**

The unit can be transported either horizontally or vertically. Make sure that the unit is correctly fastened during transportation, and cannot roll or fall over.

### 2.2.2 Lifting



#### **WARNING: Crush Hazard**

1) Always lift the unit by its designated lifting points. 2) Use suitable lifting equipment and ensure that the product is properly harnessed. 3) Wear personal protective equipment. 4) Stay clear of cables and suspended loads.



#### **WARNING: Crush Hazard**

The shaft end may slip out of a sling and lead to injury. Do not attach sling ropes to shaft ends.

Always lift the unit by its two lifting eyebolts.

#### **NOTICE:**

Never lift the unit by the motor cable or by the hose.

#### **Lifting eyebolts**

When lifting eyebolts are used for lifting the unit, the following guidelines apply:

- they always have to be screwed in firmly against the base
- the angle between them must not be greater than 90°

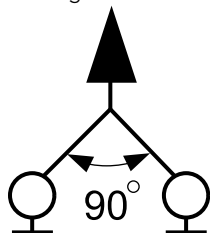

#### **Lifting equipment**

Lifting equipment is always required to handle the unit. The lifting equipment must fulfill the following requirements:

- The minimum height between the lifting hook and the floor must be sufficient to lift the unit. Contact a Xylem representative for more information.
- The lifting equipment must be able to hoist the unit straight up and down, preferably without the need for resetting the lifting hook.
- The lifting equipment must be correctly anchored and in good condition.
- The lifting equipment must support the weight of the entire assembly. Only authorized personnel may use the lifting equipment.
- Two sets of lifting equipment must be used to lift the unit for repair work.
- The lifting equipment must be dimensioned to lift the unit with any remaining pumped media in it.
- The lifting equipment must not be oversized.



#### **CAUTION: Crush Hazard**

Over-dimensioned lifting equipment can lead to injury. A site-specific risk analysis must be done.

## 2.3 Temperature ranges for transportation, handling and storage

#### **Handling at freezing temperature**

At temperatures below freezing, the product and all installation equipment, including the lifting gear, must be handled with extreme care.

Make sure that the product is warmed up to a temperature above the freezing point before starting up. Avoid rotating the impeller/propeller by hand at temperatures below the freezing point. The recommended method to warm the unit up is to submerge it in the liquid which will be pumped or mixed.

#### **NOTICE:**

Never use a naked flame to thaw the unit.

#### **Unit in as-delivered condition**

If the unit is still in the condition in which it left the factory - all packing materials are undisturbed - then the acceptable temperature range during transportation, handling and storage is: -50°C (-58°F) to +60°C (+140°F).

If the unit has been exposed to freezing temperatures, then allow it to reach the ambient temperature of the sump before operating.

#### **Lifting the unit out of liquid**

The unit is normally protected from freezing while operating or immersed in liquid, but the impeller/propeller and the shaft seal may freeze if the unit is lifted out of the liquid into a surrounding temperature below freezing.

Follow these guidelines to avoid freezing damage:

1. Empty all pumped liquid, if applicable.
2. Check all liquids used for lubrication or cooling, both oil and water-glycol mixtures, for the presence of unacceptable amounts of water. Change if needed.

Water-glycol mixtures: Units equipped with an internal closed-loop cooling system are filled with a mixture of water and 30% glycol. This mixture remains a flowing liquid at temperatures down to -13°C (9°F). Below -13°C (9°F), the viscosity increases such that the glycol mixture will lose its flow properties. However, the glycol-water mixture will not solidify completely and thus cannot harm the product.

## 2.4 Storage guidelines

#### **Storage location**

The product must be stored in a covered and dry location free from heat, dirt, and vibrations.

#### **NOTICE:**

Protect the product against humidity, heat sources, and mechanical damage.

#### **NOTICE:**

Do not place heavy weights on the packed product.

#### **Long-term storage**

If the unit is stored more than six months, then the following apply:

- Before operating the unit after storage, it must be inspected with special attention to the seals and the cable entry.
- The impeller/propeller must be rotated every other month to prevent the seals from sticking together.

### 3 Product Description



#### 3.1 Products included

Pump model	Standard	EX
1325.090		X
1325.181	X	

#### 3.2 Pump design

The pump is submersible, and driven by an electric motor.

##### Intended use

The product is intended for moving wastewater, sludge, raw and clean water. Always follow the application limits that are given in [Technical Reference](#) on page 20. If there is a question regarding the intended use of the equipment, please contact a local sales and service representative before proceeding.



##### **DANGER: Explosion/Fire Hazard**

Special rules apply to installations in explosive or flammable atmospheres. Do not install the product or any auxiliary equipment in an explosive zone unless it is rated explosion-proof or intrinsically-safe. If the product is rated explosion-proof or intrinsically-safe, then see the specific explosion-proof information in the safety chapter before taking any further actions.

##### **NOTICE:**

Do NOT use the unit in highly corrosive liquids.

##### Spare parts

- Modifications to the unit or installation should only be carried out after consulting with Xylem.
- Original spare parts and accessories that are authorized by Xylem are essential for compliance. The use of other parts can invalidate any claims for warranty or compensation. For more information contact your Xylem representative.

##### Model variants

- M Medium head
- H High head
- S Super high head

##### Parts

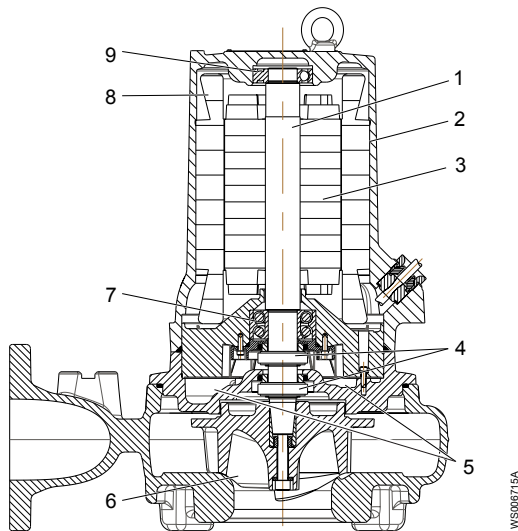

Position	Denomination	Description
1	Shaft	Stainless steel with an integrated rotor
2	Stator housing	Cooled by ambient liquid
3	Motor	For information about the motor, see <a href="#">Technical Reference</a> on page 20.
4	Mechanical seal	Inner seal: carbon/aluminium oxide CSB/Al <sub>2</sub> O <sub>3</sub> Outer seal: corrosion-resistant cemented carbide/aluminium oxide WCCR/Al <sub>2</sub> O <sub>3</sub>
5	Oil housing	Includes coolant that lubricates and cools the seals; acts as a buffer between the pumped fluid and the electric motor
6	Impeller	Non-clog
7	Main bearing	Two-row angular contact ball bearing
8	Thermal contact	The pump is equipped with thermal contacts, see <a href="#">Monitoring Equipment</a> on page 6 .
9	Support bearing	Single-row ball bearing

#### 3.3 Monitoring Equipment

The following applies to the monitoring equipment of the pump:

- The stator incorporates thermal contacts that are connected in series that activate the alarm at overtemperature.
- The thermal contacts open at 140°C (285°F).
- Ex-approved pumps must have thermal contacts that are connected to the control panel.
- The sensors must be connected to either the SMR 311 monitoring equipment or equivalent equipment.
- The monitoring equipment must be of a design that makes automatic restart impossible.
- Information in the junction box shows if the pump is equipped with optional sensors

##### Optional sensors

LD LD is a miniature float switch for detection of liquid in the stator housing. Due to its design, it is best suited for pumps in a vertical position. The LD sensor is installed in the bottom of the stator housing.

#### 3.4 The data plate

The data plate is a metal label that is located on the main body of the products. The data plate lists key product specifications. Specially approved products also have an approval plate.

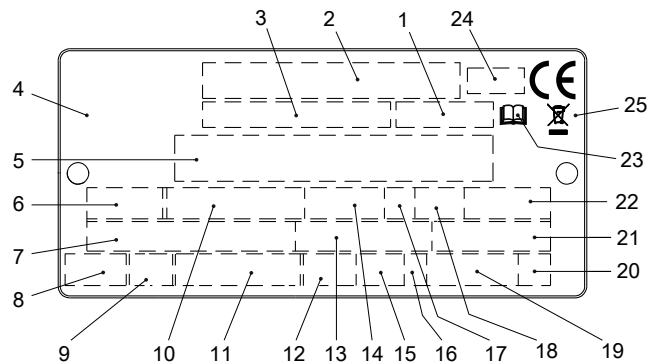

1. Curve code or Propeller code
2. Serial number
3. Product number
4. Country of origin
5. Additional information
6. Phase; type of current; frequency

7. Rated voltage
8. Thermal protection
9. Thermal class
10. Rated shaft power
11. International standard
12. Degree of protection
13. Rated current
14. Rated speed
15. Maximum submergence
16. Direction of rotation: L=left, R=right
17. Duty class
18. Duty factor
19. Product weight
20. Locked rotor code letter
21. Power factor
22. Maximum ambient temperature
23. Read installation manual
24. Notified body, only for EN-approved Ex products
25. WEEE-Directive symbol

Figure 1: The data plate

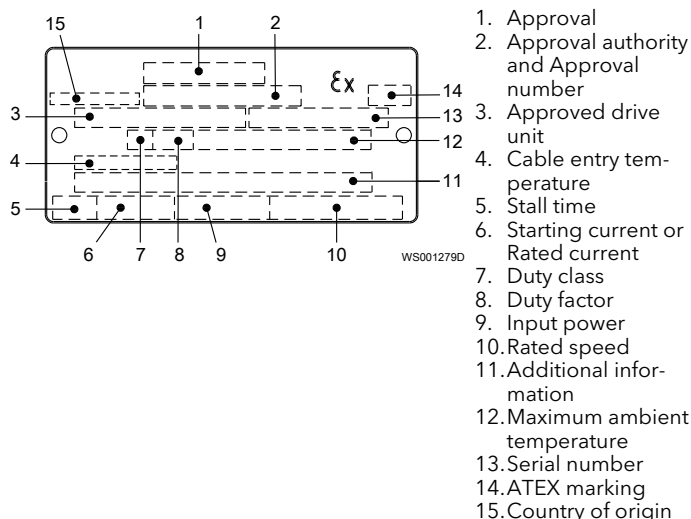

### 3.5 Approvals

#### Product approvals for hazardous locations

Pump	Approval
1325.090	European Norm (EN) <ul style="list-style-type: none"> <li>• ATEX Directive</li> <li>• EN 60079-0:2012/A11:2013, EN 60079-1:2014, EN 13463-1:2009, EN 13463-5:2011</li> <li>•  <ul style="list-style-type: none"> <li>II 2 G c Ex db IIB T3 Gb</li> </ul> </li> </ul>
	IEC <ul style="list-style-type: none"> <li>• IECEx scheme</li> <li>• IEC 60079-0:2011, IEC 60079-1:2014</li> <li>• Ex d IIB T3 Gb</li> </ul>

#### EN approval plate

This illustration describes the EN approval plate and the information that is contained in its fields.

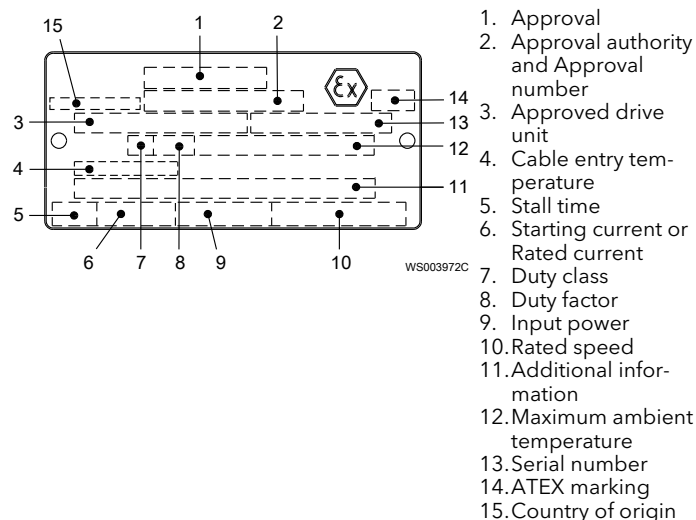

#### IEC approval plate

This illustration describes the IEC approval plate and the information that is contained in its fields.  
International Norm; not for EU member countries.

### 3.6 Product denomination

#### Reading instruction

In this section, code characters are illustrated accordingly:

X = letter

Y = digit

The different types of codes are marked up with a, b and c. Code parameters are marked up with numbers.

#### Codes and parameters

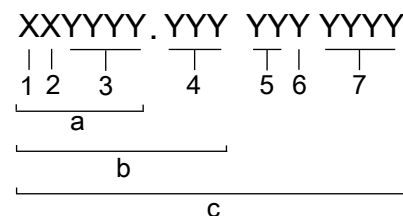

WS006265B

Type of Callout	Number	Indication
Type of code	a	Sales denomination
	b	Product code
	c	Serial number
Parameter	1	Hydraulic end
	2	Type of installation
	3	Sales code
	4	Version
	5	Production year
	6	Production cycle
	7	Running number

## 4 Installation



### 4.1 Precautions

Before starting work, make sure that the safety instructions in the chapter *Introduction and Safety* on page 3 have been read and understood.

**DANGER: Electrical Hazard**

Before starting work on the unit, make sure that the unit and the control panel are isolated from the power supply and cannot be energized. This applies to the control circuit as well.

**DANGER: Inhalation Hazard**

Before entering the work area, make sure that the atmosphere contains sufficient oxygen and no toxic gases.

**4.1.1 Hazardous atmospheres****DANGER: Explosion/Fire Hazard**

Special rules apply to installations in explosive or flammable atmospheres. Do not install the product or any auxiliary equipment in an explosive zone unless it is rated explosion-proof or intrinsically-safe. If the product is rated explosion-proof or intrinsically-safe, then see the specific explosion-proof information in the safety chapter before taking any further actions.

**General requirements**

These requirements apply:

- Use the pump dimensional drawing in order to ensure proper installation.

Before installing the pump, do the following:

- Provide a suitable barrier around the work area, for example, a guard rail.
- Make sure that equipment is in place so that the unit cannot roll or fall over during the installation process.
- Check the explosion risk before you weld or use electric hand tools.
- Check that the cable and cable entry have not been damaged during transport.
- Always remove all debris and waste material from the sump, inlet piping, and discharge connection, before you install the pump.
- Always check the impeller rotation before lowering the pump into the pumped liquid.

**NOTICE:**

Do not run the pump dry.

**NOTICE:**

Never force piping to make a connection with a pump.

**Authority regulation**

Vent the tank of a sewage station in accordance with local plumbing codes.

**Fasteners**

- Only use fasteners of the correct size and material.
- Replace all corroded or damaged fasteners.
- Make sure that all the fasteners are correctly tightened and that there are no missing fasteners.

**4.1.2 Install with Wet well installation**

In the wet-well installation, the pump is installed on a stationary discharge connection, and operates either completely or partially submerged in the pumped liquid. These requirements and instructions only apply when the installation is made according to the dimensional drawing.

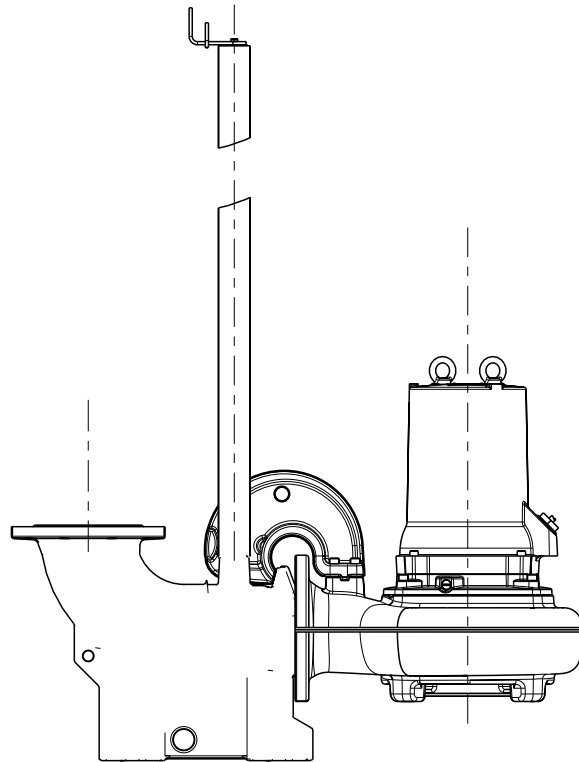

WS006192A

**Figure 2: Wet well installation**

These items are required:

- Guide bars
- Guide bar bracket for attaching the guide equipment to the access frame or to the upper part of the sump
- Level regulators or other control equipment for start, stop, and alarm
- Cable holder for holding the cable and regulating the height of the level regulators
- Access frame (with covers) to which the upper guide bar bracket and cable holder can be attached
- Discharge connection for connecting the pump to the discharge line

The discharge connection has a flange which fits the pump housing flange and a bracket for attaching the guide equipment.

- Fasteners for the discharge connection
  - Anchor bolts
1. Run a cable between the sump and the stator and monitoring equipment.  
Make sure that the cable is not sharply bent or pinched.
  2. Install the access frame:
    - a) Place the access frame in position and align it horizontally.
    - b) Grout the frame in place.
  3. Grout the anchor bolts in place.  
Be careful when you align and position the discharge connection in relation to the access frame.
  4. Place the discharge connection in position, and tighten the nuts.
  5. Install the guide bars:
    - a) Secure the guide bars in the bracket.
    - b) Check that the guide bars are placed vertically. Use a level or a plumb line.
  6. Connect the discharge pipe to the discharge connection.
  7. Prepare for the level regulator:
    - a) Bolt the cable holder to the access frame.
    - b) Attach the level regulator cable to the cable holder and adjust the height of the level regulator.
    - c) Protect bolts and nuts with a corrosion-preventive compound.
  8. Lower the pump along the guide bars.
  9. Secure the motor cable:

- a) Fasten the permanent lifting device to the pump and to the access frame. For example, you can use a stainless-steel lifting chain with shackles.
- b) Fasten the cable to the cable holder.  
Make sure that the cable cannot be sucked into the pump inlet or that it is neither sharply bent, or pinched. Support straps are required for deep installations.
- c) Connect the motor cable and the starter and monitoring equipment according to the separate instructions.  
Make sure that the impeller rotation is correct. For more information, see [Check the impeller rotation](#) on page 13.

Clean all debris from the sump before starting the pump.

### 4.1.3 Install with Free-standing installation

In the Free-standing installation, the pump is transportable and intended to operate either completely or partially submerged in the pumped liquid. The pump is equipped with a connection for hose or pipe and stands on a base stand.

These requirements and instructions only apply when the installation is made according to the dimensional drawing.

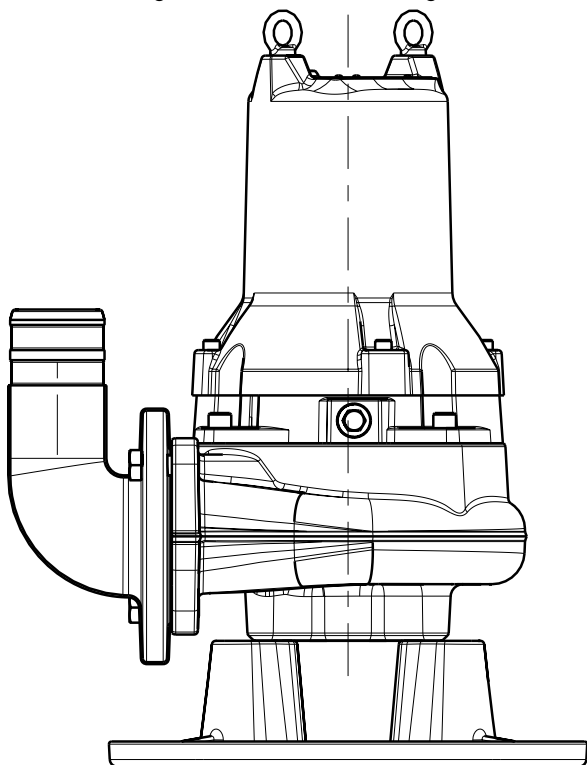

Figure 3: Free-standing installation

1. Run the cable so that it has no sharp bends. Make sure that it is not pinched, and cannot be sucked into the pump inlet.
2. Connect the discharge line.
3. Lower the pump into the sump.
4. Place the pump on the base and make sure it cannot fall over or sink.  
Alternatively, the pump can be suspended with a lifting chain just above the sump bottom. Make sure that the pump cannot rotate at startup or during operation.
5. Connect the motor cable and the starter and monitoring equipment according to the separate instructions.

## 4.2 Make the electrical connections

### 4.2.1 General precautions



#### **DANGER: Electrical Hazard**

Before starting work on the unit, make sure that the unit and the control panel are isolated from the power supply and cannot be energized. This applies to the control circuit as well.



#### **WARNING: Electrical Hazard**

Risk of electric shock or burn. A certified electrician must supervise all the electrical work. All the local codes and regulations must be obeyed.



#### **WARNING: Electrical Hazard**

There is a risk of electrical shock or explosion if the electrical connections are not correctly carried out, or if there is fault or damage on the product. Visually inspect equipment for damaged cables, cracked casings or other signs of damage. Make sure that electrical connections have been correctly made.



#### **WARNING: Crush Hazard**

Risk of automatic restart.



#### **CAUTION: Electrical Hazard**

Prevent cables from becoming sharply bent or damaged.

#### **NOTICE:**

Leakage into the electrical parts can cause damaged equipment or a blown fuse. Keep the cable ends dry at all times.

#### **Requirements**

These general requirements apply for the electrical installation:

- if the pump will be connected to the public mains, then the supply authority must be notified before installing the pump. When the pump is connected to the public power supply, it can cause flickering of incandescent lamps when started.
- The mains voltage and frequency must agree with the specifications on the data plate. If the pump can be connected to different voltages, then follow the specified voltage on the yellow sticker close to the cable entry.
- If the operation can be intermittent, then the pump must be supplied with monitoring equipment supporting such operation.
- If stated on the data plate, then the motor is convertible between different voltages.
- The thermal contacts or thermistors must be in use.

#### **Motor and short-circuit protection**

A qualified electrician must select the size of motor protection breakers and fuses, so that it is sufficient for the specific motor data such as rated current and starting current.

It is important that the short-circuit protection is not over-dimensioned. Over-dimensioned fuses and motor protection breakers decrease the protection for the motor.

- The fuse rating and the cables must be in accordance with the local rules and regulations.
- The fuses and circuit breakers must have the correct rating. The pump overload protection must be connected and set to the rated current. See the data plate and if applicable the cable chart for the rated current. The starting current in direct-on-line start can be up to six times higher than the rated current.

**Cables**

These are the requirements to follow when you install cables:

- The cables must be in good condition, not have any sharp bends, and not be pinched.
- The cables must not be damaged and must not have indentations or be embossed (with markings, etc.) at the cable entry.
- The cable entry seal sleeve and washers must conform to the outside diameter of the cable.
- The minimum bending radius must not be below the accepted value.
- If using a cable which has been used before, a short piece must be peeled off when refitting it so that the cable entry seal sleeve does not close around the cable at the same point again. If the outer sheath of the cable is damaged, then replace the cable.
- Contact a sales or authorized service representative.
- The voltage drop in long cables must be taken into account. The drive unit's rated voltage is the voltage measured at the cable connection point in the pump.
- For SUBCAB® cables, the twisted pair copper foil must be trimmed.
- All unused conductors must be insulated.

**4.2.2 Grounding (earthing)**

Grounding (earthing) must be done in compliance with all local codes and regulations.



**DANGER: Electrical Hazard**

All electrical equipment must be grounded (earthed). Test the ground (earth) lead to verify that it is connected correctly and that the path to ground is continuous.



**WARNING: Electrical Hazard**

If the power cable is jerked loose, then the ground (earth) conductor must be the last conductor to come loose from its terminal. Make sure that the ground (earth) conductor is longer than the phase conductors at both ends of the cable.



**WARNING: Electrical Hazard**

Risk of electrical shock or burn. You must connect an additional ground- (earth-) fault protection device to the grounded (earthed) connectors if persons are likely to come into contact with liquids that are also in contact with the pump or pumped liquid.

**4.2.3 Prepare the SUBCAB™ cables**

This section applies to SUBCAB™ cables with twisted-pair control cores.

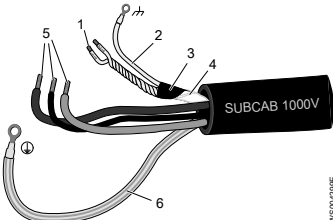
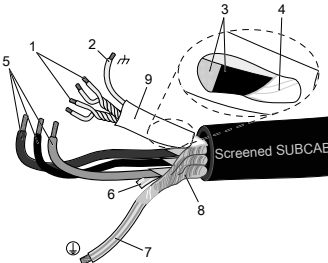
The prepared SUBCAB™ cable	The prepared screened SUBCAB™ cable, without cable lugs
 <ol style="list-style-type: none"> <li>1. T1+T2 twisted pairs in control element</li> <li>2. Drain wire in control element (bare aluminum wire)</li> <li>3. Aluminum foil, screen</li> <li>4. Insulation sheath (plastic jacket) or PT-foil for control element</li> <li>5. Power cores</li> <li>6. Ground (earth) core</li> </ol>	 <ol style="list-style-type: none"> <li>1. T1+T2 and T3+T4 twisted pairs in control element</li> <li>2. Drain wire in control element (tinned copper strands) with shrink hose</li> <li>3. Aluminum and textile layers</li> <li>4. Insulation sheath or plastic jacket, for the control element</li> <li>5. Power cores</li> <li>6. Plastic laminated aluminum foil, screen</li> <li>7. Ground (earth) core with yellow-green shrink hose</li> <li>8. Uncovered screen/braided wire</li> <li>9. Shrink hose</li> </ol>

1. Peel off the outer sheath at the end of the cable.
2. Prepare the control element:
  - a) Peel the sheath (if applicable) and the aluminum foil. The aluminum foil is a screen and is conductive. Do not peel more than necessary, and remove the peeled foil.

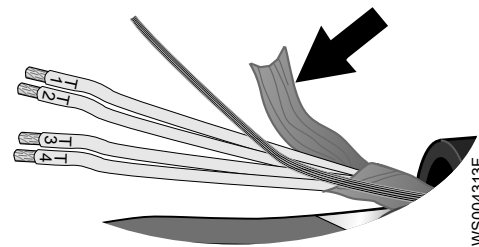

**Figure 4: Aluminum foil on control element.**

- b) Put a white shrink hose over the drain wire and the cable terminal.
- c) Fit a cable lug on the drain wire.
- d) Twist T1+T2 and T3+T4.
- e) Put a shrink hose over the control element. Make sure that the conductive aluminum foil and drain wire is covered.
3. Prepare the ground (earth) core for SUBCAB™ cable:
  - a) Peel the yellow-green insulation from the ground (earth) core.
  - b) Check that the ground (earth) core is at least 10% longer than the phase cores in the cabinet.
  - c) If applicable, put a cable lug on the ground core.
4. Prepare the ground (earth) core for screened SUBCAB™ cable:
  - a) Untwist the screens around the power cores.
  - b) Put a yellow-green shrink hose over the ground (earth) core. Leave a short piece uncovered.
  - c) If applicable, put a cable lug on the screened ground core.
  - d) Twist all power core screens together to create a ground (earth) core and fit a cable terminal to the end.
  - e) Check that the ground (earth) core is at least 10% longer than the phase cores in the cabinet.
5. Connect to ground (earth):
  - Screw: Fit cable terminals to the ground (earth) core and the power cores.
  - Terminal block: Leave the core ends as they are.
6. Prepare the main leads:
  - a) Remove the aluminum foil around each power core.
  - b) Peel the insulation from each power core.

**4.2.4 Connect the motor cable to the pump**

**NOTICE:**

Leakage into the electrical parts can cause damaged equipment or a blown fuse. Keep the end of the motor cable dry at all times.

1. Remove the entry gland screw from the stator housing.
2. Remove the stator housing. This provides access to the terminal block/closed end splices.
3. Check the data plate to see which connections are required for the power supply.
4. Arrange the connections on the terminal block/closed end splices in accordance with the required power supply.
5. Connect the mains leads (L1, L2, L3, and ground (earth) ) according to applicable cable chart. The ground (earth) lead must be 50 mm (2.0 in.) longer than the phase conductors in the junction box of the unit.
6. Make sure that the pump is correctly connected to ground (earth).
7. Make sure that any thermal contacts incorporated in the pump are properly connected to the terminal block/closed end splices.
8. Install the stator housing.
9. Install the entry gland screw on the stator housing.

### 4.2.5 Connect the motor cable to the starter and monitoring equipment



**DANGER: Explosion/Fire Hazard**

Special rules apply to installations in explosive or flammable atmospheres. Do not install the product or any auxiliary equipment in an explosive zone unless it is rated explosion-proof or intrinsically-safe. If the product is rated explosion-proof or intrinsically-safe, then see the specific explosion-proof information in the safety chapter before taking any further actions.

**NOTICE:**

Thermal contacts are incorporated in the pump.

**NOTICE:**

Thermal contacts must never be exposed to voltages higher than 250 V, breaking current maximum 5 A.

1. If thermal contacts are included in the pump installation, then connect the T1 and T2 control conductors to the MiniCAS II monitoring equipment.  
If the temperature of the pumped liquid is above 40°C (104°F), then do not connect the T1 and T2 leads to thermal contacts.

**NOTICE:**

The thermal contacts are incorporated in the stator. Connect them to 24 V over separate fuses to protect other automatic equipment.

2. Connect the mains leads (L1, L2, L3, and ground (earth)) to the starter equipment.  
For information about the phase sequence and the color codes of the leads, see Cable charts.
3. Check the functionality of the monitoring equipment:
  - a) Check that the signals and the tripping function work correctly.
  - b) Check that the relays, lamps, fuses, and connections are intact.
 Replace any defective equipment.

### 4.2.6 Cable charts

**Description**

This topic contains general connection information. It also provides cable charts that show connection alternatives for use with different cables and power supply.

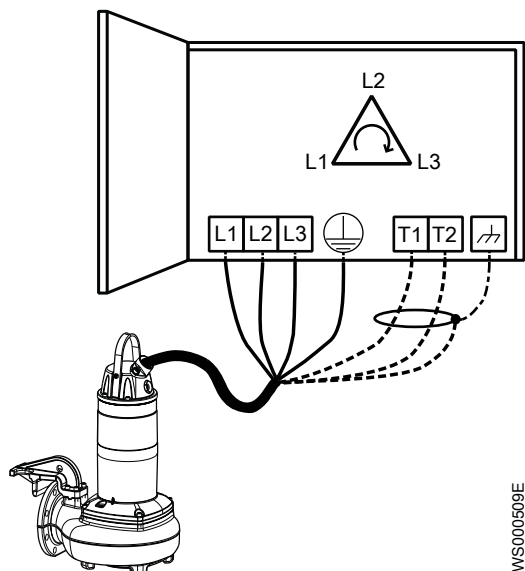
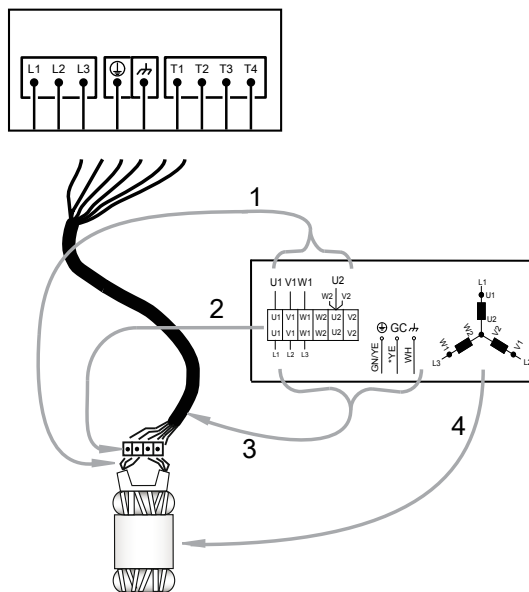

Figure 5: Phase sequence

WS000509E

### Connection locations

The figures in this section illustrate how to interpret the connection strip symbols.



1. Stator leads
2. Terminal board
3. Motor cable leads
4. Stator (internal connection illustrated)

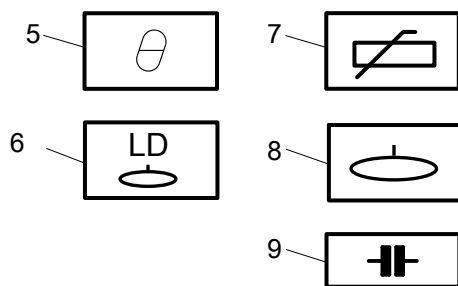
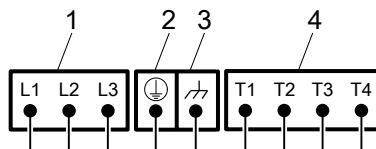

1. Starter equipment and mains leads (L1, L2, L3)
2. Ground (earth)
3. Functional ground
4. Control leads (T1, T2, T3, T4)
5. Thermal contact
6. Leakage detector (LD)
7. Thermistor
8. Level sensor
9. Capacitor

### Color code standard

Code	Description
BN	Brown
BK	Black
WH	White

WS007735A

WS004846B

Code	Description
OG	Orange
GN	Green
GNYE	Green-Yellow
RD	Red
GY	Grey
BU	Blue
YE	Yellow

Colors and marking of leads

Motor connection		Mains	SUBCAB 7GX	H07RN-F	SUBCAB 4GX	SUBCAB AWG
Colors and marking of main leads		1 2 3				
COLOR STANDARD		1	L1	BK 1	BK 1	BN
STATOR LEADS		2	L2	BK 2	BK 2	BK
BN = Brown		3	L3	BK 3	BK 3	GY
BK = Black						
WH = White						
OG = Orange						
GN = Green						
GNYE = Green-Yellow						
RD = Red						
GY = Grey						
BU = Blue						
YE = Yellow						
*SUBCAB AWG						
** Ground Conductor is stranded around cores						
GC=Ground Check						
772 17 05/rev4		GC	-	-	-	YE

Figure 6: Motor connection

4.2.6.1 3-phase connection

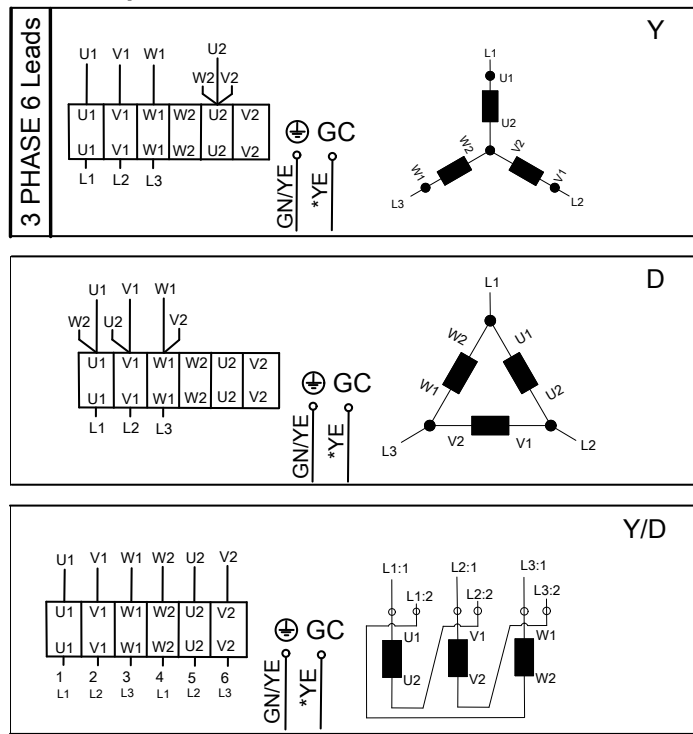

Figure 7: 6 leads

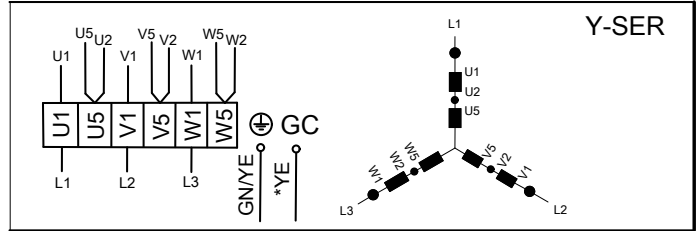
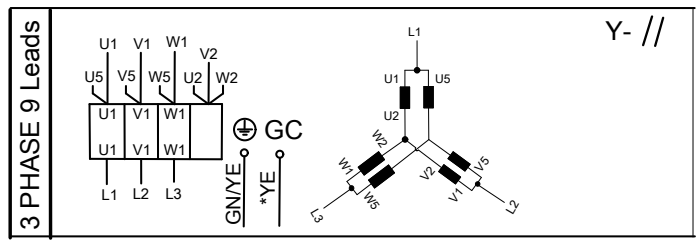

Figure 8: 9 leads

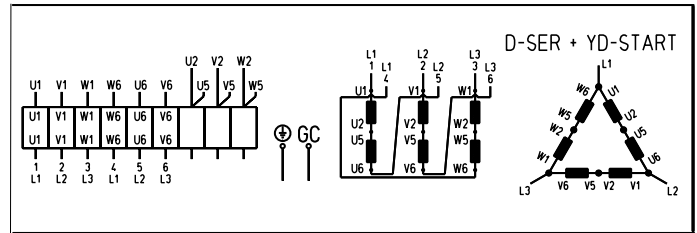
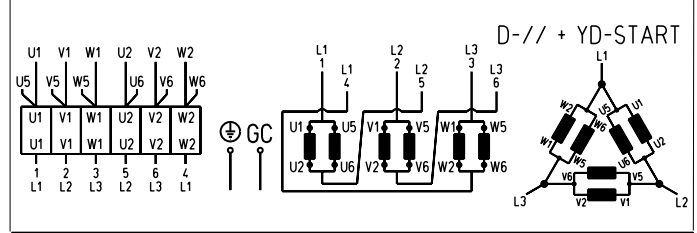
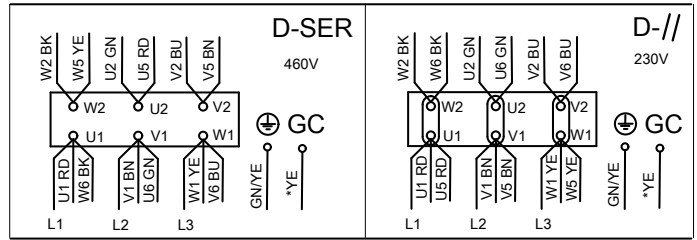
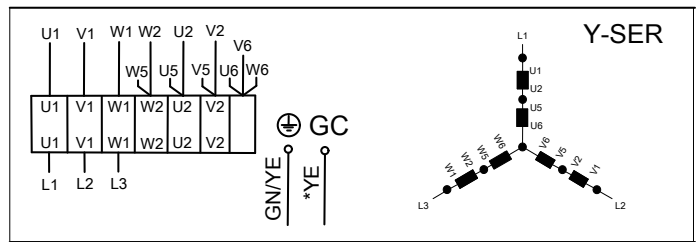
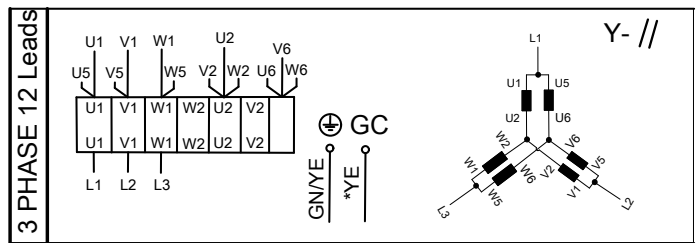

Figure 9: 12 leads



**Noise level****NOTICE:**

The sound power level of the product is lower than 70 dB(A). However, in some installations the resulting sound pressure level may exceed 70 dB(A) at certain operating points on the performance curve. Make sure that you understand the noise level requirements in the environment where the product is installed. Failure to do so may result in hearing loss or violation of local laws.

**5.2 Start the pump****CAUTION: Crush Hazard**

The starting jerk can be powerful. Make sure nobody is close to the unit when it is started.

**NOTICE:**

Make sure that the rotation of the impeller is correct. For more information, see Check the impeller rotation.

1. Check the coolant level in the seal housing.
2. Remove the fuses or open the circuit breaker, and check that the impeller can rotate freely.

**WARNING: Crush Hazard**

Never put your hand into the pump housing.

3. Conduct insulation test phase to ground. To pass, the value must exceed 5 megaohms.
4. Start the pump.

**6 Maintenance****6.1 Precautions**

Before starting work, make sure that the safety instructions in the chapter *Introduction and Safety* on page 3 have been read and understood.

**DANGER: Crush Hazard**

Moving parts can entangle or crush. Always disconnect and lock out power before servicing to prevent unexpected start-up. Failure to do so could result in death or serious injury.

**WARNING: Biological Hazard**

Infection risk. Rinse the unit thoroughly with clean water before working on it.

**CAUTION: Crush Hazard**

Make sure that the unit cannot roll or fall over and injure people or damage property.

Make sure that you follow these requirements:

- Check the explosion risk before you weld or use electrical hand tools.
- Allow all system and pump components to cool before you handle them.
- Make sure that the product and its components have been thoroughly cleaned.
- Before starting work, make sure that the work area is well-ventilated.
- Do not open any vent or drain valves or remove any plugs while the system is pressurized. Make sure that the pump is isolated from the system and that pressure is relieved before you disassemble the pump, remove plugs, or disconnect piping.

**Ground continuity verification**

A ground (earth) continuity test must always be performed after service.

**Maintenance guidelines**

During the maintenance and before reassembly, always remember to perform these tasks:

- Clean all parts thoroughly, particularly O-ring grooves.
- Change all O-rings, gaskets, and seal washers.
- Lubricate all springs, screws, O-rings with grease.

During the reassembly, always make sure that existing index markings are in line.

The reassembled drive unit must always be insulation-tested and the reassembled pump must always be test-run before normal operation.

**6.2 Change the coolant**

This image shows the plugs that are used to change the coolant.

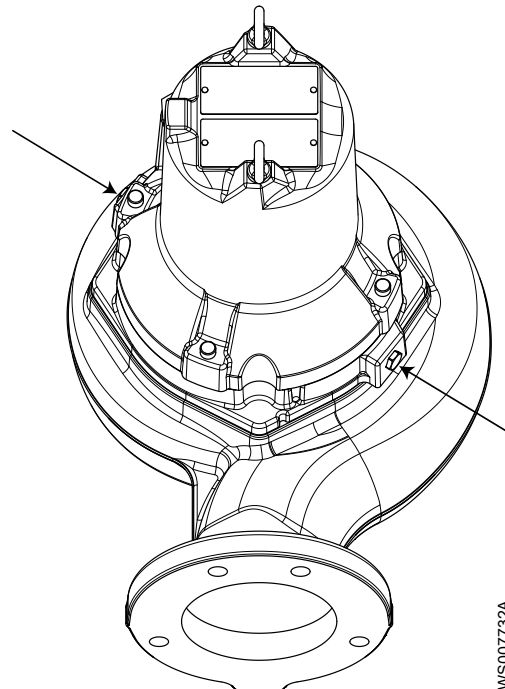

1. Coolant plugs

**6.2.1 Empty the coolant****CAUTION: Compressed Gas Hazard**

Air inside the chamber may cause parts or liquid to be propelled with force. Be careful when opening. Allow the chamber to de-pressurize before removal of the plug.

1. Place the pump in a horizontal position and unscrew the coolant plug.

If the pump has a hole with the markings "oil out" it is important that this hole is used for drainage.

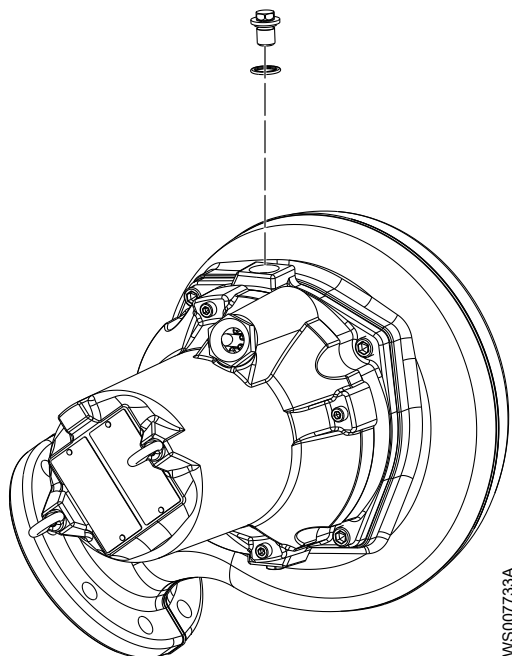

WS007733A

2. Place a container under the pump and turn the pump.

3. Unscrew the other coolant plug.

If this hole has the marking "oil in", the pump must be raised up-right for a short while during drainage in order to drain all the coolant.

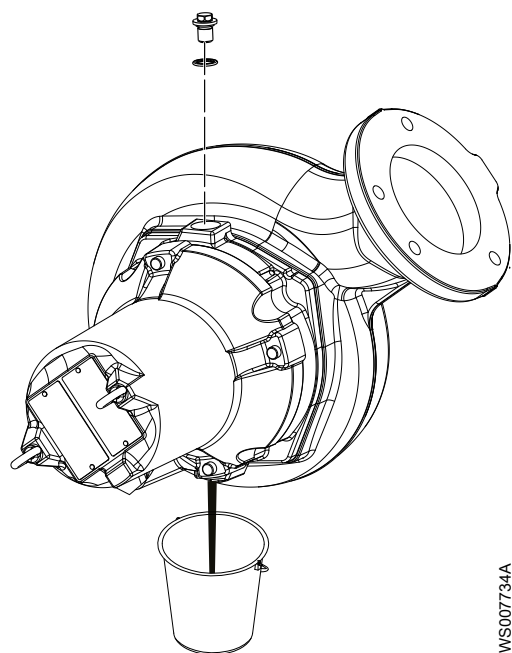

WS007734A

### 6.2.2 Fill with coolant

Use oil as coolant. The oil should be a paraffin oil with viscosity close to ISO VG32. Examples of suitable oil types are the following:

- Statoil MedicWay 32™
- BP Enerpar M 004™
- Shell Ondina 927™
- Shell Ondina X430™

1. Replace the O-rings of the coolant plugs.
2. Refit a coolant plug in the hole that faces downwards or is marked "oil out" and tighten.

Tightening torque: 20 Nm (15 ft-lbs)

3. Fill with coolant through the hole on the opposite side or the hole marked "oil in".

If the hole is marked "oil in" the pump has to be tilted slightly and lowered again in order to fill the pump with the correct quantity.

Quantity: approximately 2.1 liters (2.2 quarts)

4. Refit the remaining coolant plug and tighten.

Tightening torque: 20 Nm (15 ft-lbs)

## 6.3 Service the pump

Type of maintenance	Purpose	Inspection interval
Initial inspection	A Xylem-authorized personnel checks the pump condition. From the results, the personnel recommends the intervals for the periodical inspection and overhaul for the installation.	Within the first year of operation.
Periodical inspection	The inspection prevents operational interruptions and machine breakdowns. The measures to increase performance and pump efficiency are decided for each application. They can include such things as impeller trimming, wear part control and replacement, control of zinc-anodes and control of the stator.	Up to every year Applies to normal applications and operating conditions at media (liquid) temperatures <40°C (104°F).
Overhaul	The overhaul lengthens the operating lifetime of the product. It includes the replacement of key components and the measures that are taken during an inspection.	Up to every two years Applies to normal applications and operating conditions at media (liquid) temperatures <40°C (104°F).

### NOTICE:

Shorter intervals may be required when the operating conditions are extreme, for example with very abrasive or corrosive applications or when the liquid temperatures exceed 40°C (104°F).

### 6.3.1 Inspection

Service item	Action
Cable	<ol style="list-style-type: none"> <li>1. If the outer jacket is damaged, then replace the cable.</li> <li>2. Check that the cables do not have any sharp bends and are not pinched.</li> </ol>
Connection to power	Check that the connections are properly secured.
Electrical cabinets	Check that they are clean and dry.
Impeller	<ol style="list-style-type: none"> <li>1. Check the impeller clearance.</li> <li>2. Adjust the impeller, if necessary.</li> </ol>
Stator housing	<ol style="list-style-type: none"> <li>1. Drain all liquid, if any.</li> <li>2. Check the resistance of the leakage sensor. Normal value approximately 1530 ohms, alarm approximately 330 ohms.</li> </ol>
Insulation	<p>Use a megger maximum 1000 V.</p> <ol style="list-style-type: none"> <li>1. Check that the resistance between the ground (earth) and phase lead is more than 5 megohms.</li> <li>2. Conduct a phase-to-phase resistance check.</li> </ol>
Junction box	Check that it is clean and dry.
Level regulators	Check the condition and functionality.
Lifting device	Check that the local safety regulations are followed.

Service item	Action
Lifting eye bolts	<ol style="list-style-type: none"> <li>1. Check that they are screwed firmly against the base.</li> <li>2. Check that they are situated on same plane.</li> <li>3. Check the condition of the lifting eye bolt.</li> <li>4. If necessary, replace.</li> </ol>
O-rings	<ol style="list-style-type: none"> <li>1. Replace the coolant plug O-rings.</li> <li>2. Grease the O-rings.</li> </ol>
Personnel safety devices	Check the guard rails, covers, and other protections.
Rotation direction	Check the impeller rotation.
Oil housing	Fill with new coolant, if necessary.
Terminal block/closed end splice	Check that the connections are properly tightened/connected.
Thermal contacts	Normally closed circuit; interval 0-1 ohm.
Voltage and amperage	Check the running values.

### 6.3.2 Overhaul

The basic repair kit includes O-rings, seals, and bearings. For an overhaul, do the following in addition to the tasks listed under Inspection.

Service item	Action
Support and main bearing	Replace the bearings with new bearings.
Mechanical seal	Replace with new seal units.

### 6.3.3 Service in case of alarm

For information about indication values for sensors, see [Sensor connection characteristics](#) on page 13.

Alarm source	Action
LD	<ol style="list-style-type: none"> <li>1. Check for liquid in the stator housing.</li> <li>2. Drain all liquid, if any.</li> <li>3. Check the mechanical seal unit, the O-rings, and the cable entry, if liquid was found.</li> </ol>
Thermal contact	Check the start and stop levels.
Overload protection	Check that the impeller can rotate freely.

## 6.4 Replace the impeller

Required tools:

- 12 hexagon bit adapter with an extension of at least 100 mm (3.94 in)
  - Impeller puller
- If applicable, contact your local sales and service representative for correct type and size.
- Rod (wood or copper) for locking the impeller in place, if applicable.
  - Two crowbars, if applicable

#### NOTICE:

- If you fail with the impeller installation, you must redo the installation procedure from the beginning.
- When laying the pump on its side, do not allow the weight of the pump to rest on any portion of the impeller. The impeller must not be allowed to make contact with the concrete floor or other hard and rough surfaces.



**CAUTION: Cutting Hazard**  
Worn parts can have sharp edges. Wear protective clothing.

### 6.4.1 Remove the impeller



**CAUTION: Cutting Hazard**  
Sharp edges. Wear protective clothing.

1. Place the pump in a horizontal position.
2. Remove the impeller:
  - a) Lock the impeller in place by inserting a rod through the pump housing outlet.
  - b) Remove the impeller screw.

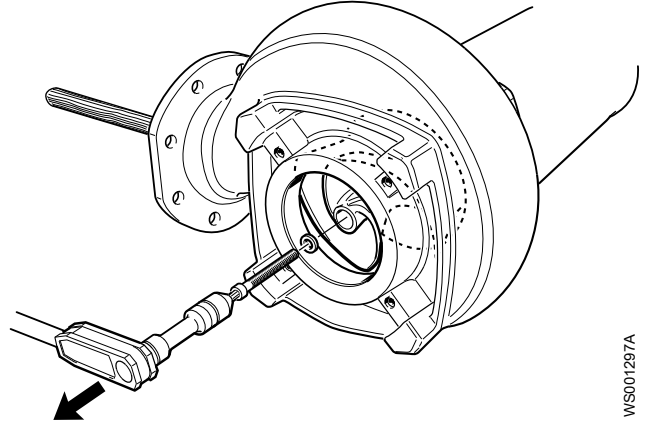

WS001287A

- c) Turn the adjustment screw counterclockwise until the impeller breaks free from the shaft.

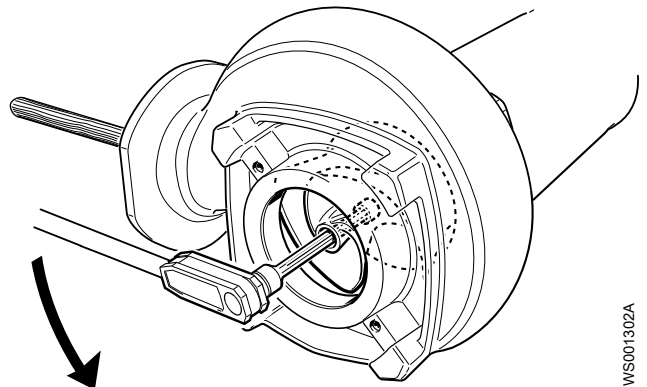

WS001302A

- d) Hand-tighten the impeller screw to prevent it from falling off.

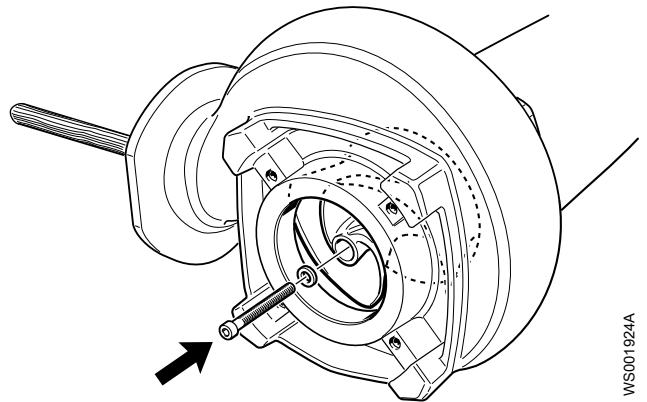

WS001924A

- e) Remove the rod.
3. Raise the pump.
  4. Remove the drive unit from the pump housing:
    - a) Remove the pump housing screws.

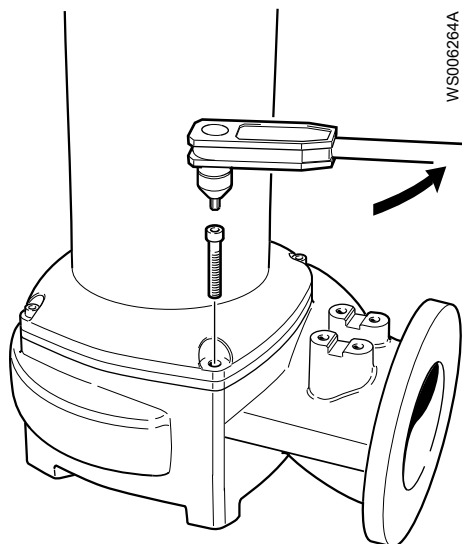

WS006264A

b) Remove the drive unit from the pump housing.

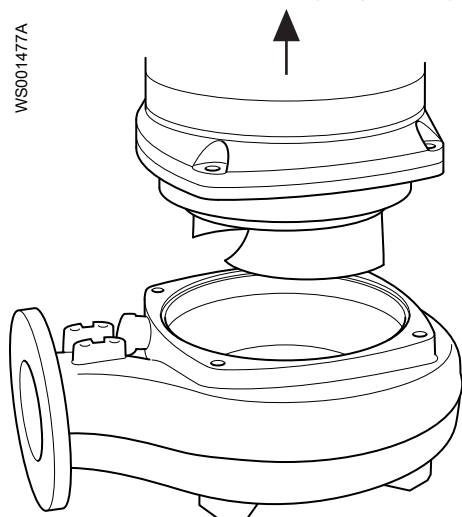

WS001477A

5. Remove the impeller:

- a) Place the drive unit horizontally.
- b) Remove the impeller screw.

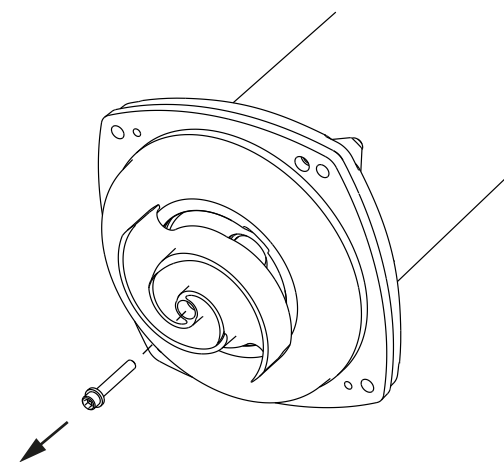

WS007960A

c) Remove the impeller and the conical sleeve.

### 6.4.2 Install the impeller

1. Prepare the shaft:

- a) Polish off any flaws with a fine emery cloth.

- b) Coat the inner conic, the outer cylindrical surfaces, and the thread of the conical sleeve with a thin layer of grease.

The proper lubrication is grease for bearings, for example Exxon Mobil Unirex N3, Mobil Mobilith SHC 220 or equivalent.

#### NOTICE:

Surplus grease can cause the impeller to become loose. Remove surplus grease from conical and/or cylindrical surfaces of shafts and/or sleeves.

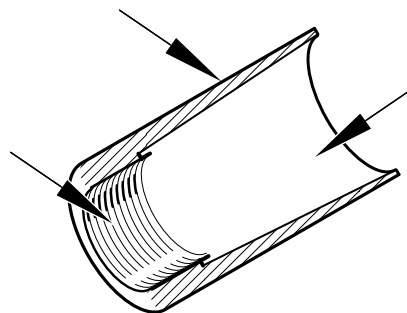

WS006895A

2. Mount the impeller:

- a) Lubricate the threads of the impeller screw and the washer. Always use a new impeller screw.
- b) Adjust the adjustment screw so that it is flush with the sleeve.

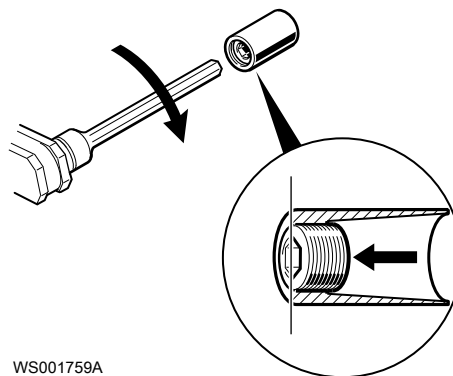

WS001759A

c) Fit the sleeve, washer, and impeller to the shaft.

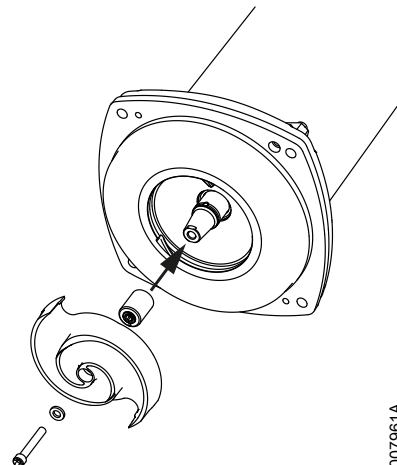

WS007961A

- d) Hand-tighten the impeller screw to prevent it from falling off.
3. Fit the pump housing:
- a) Fit a new and lubricated O-ring on the seal housing cover.
  - b) Lubricate the pump housing screws.
  - c) Raise the drive unit.
  - d) Place the drive unit into the pump housing.
  - e) Tighten the screws in diagonal sequence.

Tightening torque: 76 Nm (56 ft-lb)

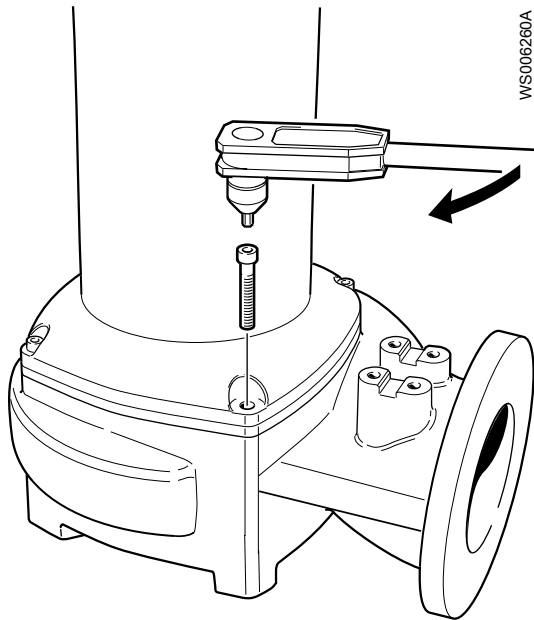

4. Remove the impeller screw:
  - a) Place the pump horizontally.
  - b) Lock the impeller in place by inserting a rod through the pump housing outlet.
  - c) Remove the impeller screw and the washer.

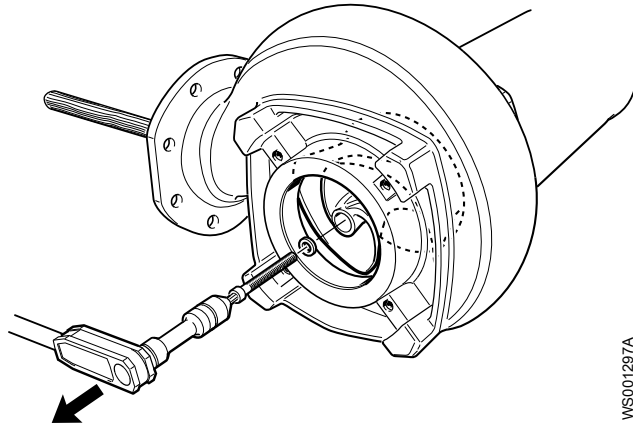

5. Adjust the impeller:
  - a) Using a hexagon-bit adapter, turn the adjustment screw clockwise until the impeller makes contact with the pump housing.
  - b) Tighten it a further 1/8 turn (45°).

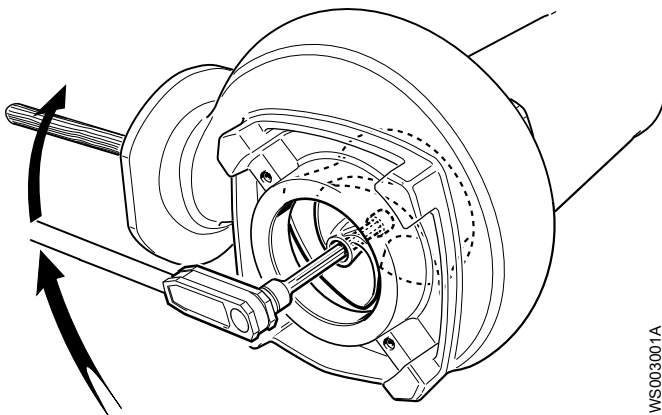

6. Fasten the impeller:
  - a) Fit the lubricated washer and impeller screw.
  - b) Tighten the impeller screw.

Tightening torque: 76 Nm (56 ft-lb)  
c) Tighten it a further 1/8 turn (45°).

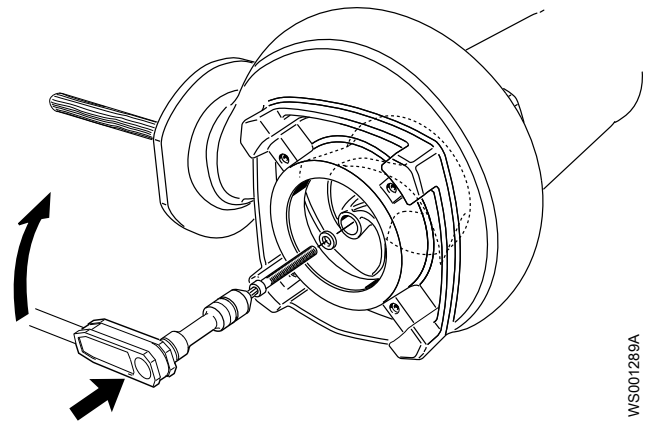

- d) Remove the rod that is used to lock the impeller.
- e) Check that the impeller can rotate freely.

## 7 Troubleshooting



### 7.1 Electrical troubleshooting



**DANGER: Electrical Hazard**

Troubleshooting a live control panel exposes personnel to hazardous voltages. Electrical troubleshooting must be done by a qualified electrician.

Follow these guidelines when troubleshooting:

- Disconnect and lock out the power supply except when conducting checks that require voltage.
- Make sure that no one is near the unit when the power supply is re-connected.
- When troubleshooting electrical equipment, use the following:
  - Universal instrument multimeter
  - Test lamp (continuity tester)
  - Wiring diagram

### 7.2 The pump does not start



**DANGER: Crush Hazard**

Moving parts can entangle or crush. Always disconnect and lock out power before servicing to prevent unexpected start-up. Failure to do so could result in death or serious injury.



**NOTICE:**

Do NOT override the motor protection repeatedly if it has tripped. Doing so may result in equipment damage.

Cause	Remedy
An alarm signal has been triggered on the control panel.	Check that: <ul style="list-style-type: none"> <li>• The impeller rotates freely.</li> <li>• The sensor indicators do not indicate an alarm.</li> <li>• The overload protection is not tripped.</li> </ul>

Cause	Remedy
The pump does not start automatically, but can be started manually.	Check that: <ul style="list-style-type: none"> <li>The start level regulator is functioning. Clean or replace if necessary.</li> <li>All connections are intact.</li> <li>The relay and contactor coils are intact.</li> <li>The control switch (Man/Auto) makes contact in both positions.</li> </ul> Check the control circuit and functions.
The installation is not receiving voltage.	Check that: <ul style="list-style-type: none"> <li>The main power switch is on.</li> <li>There is control voltage to the start equipment.</li> <li>The fuses are intact.</li> <li>There is voltage in all phases of the supply line.</li> <li>All fuses have power and that they are securely fastened to the fuse holders.</li> <li>The overload protection is not tripped.</li> <li>The motor cable is not damaged.</li> </ul>
The impeller is stuck.	Clean: <ul style="list-style-type: none"> <li>The impeller</li> <li>The sump in order to prevent the impeller from clogging again.</li> </ul>

If the problem persists, then contact a sales or authorized service representative.

Always state the serial number of the product, see [Product Description](#) on page 5.

### 7.3 The pump does not stop when a level sensor is used



#### DANGER: Crush Hazard

Moving parts can entangle or crush. Always disconnect and lock out power before servicing to prevent unexpected start-up. Failure to do so could result in death or serious injury.



Cause	Remedy
The pump is unable to empty the sump to the stop level.	Check that: <ul style="list-style-type: none"> <li>There are no leaks from the piping and/or discharge connection.</li> <li>The impeller is not clogged.</li> <li>The non-return valve(s) are functioning properly.</li> <li>The pump has adequate capacity. For information: Contact a sales or authorized service representative.</li> </ul>
There is a malfunction in the level-sensing equipment.	<ul style="list-style-type: none"> <li>Clean the level regulators.</li> <li>Check the functioning of the level regulators.</li> <li>Check the contactor and the control circuit.</li> <li>Replace all defective items.</li> </ul>
The stop level is set too low.	Raise the stop level.

If the problem persists, then contact a sales or authorized service representative.

Always state the serial number of the product, see [Product Description](#) on page 5.

### 7.4 The pump starts-stops-starts in rapid sequence

Cause	Remedy
The pump starts due to back-flow which fills the sump to the start level again.	Check that: <ul style="list-style-type: none"> <li>The distance between the start and stop levels is sufficient.</li> <li>The non-return valve(s) work(s) properly.</li> <li>The length of the discharge pipe between the pump and the first non-return valve is sufficiently short.</li> </ul>
The self-holding function of the contactor malfunctions.	Check: <ul style="list-style-type: none"> <li>The contactor connections.</li> <li>The voltage in the control circuit in relation to the rated voltages on the coil.</li> <li>The functioning of the stop-level regulator.</li> <li>Whether the voltage drop in the line at the starting surge causes the contactor's self-holding malfunction.</li> </ul>

If the problem persists, then contact a sales or authorized service representative.

Always state the serial number of the product, see [Product Description](#) on page 5.

### 7.5 The pump runs but the motor protection trips



#### DANGER: Crush Hazard

Moving parts can entangle or crush. Always disconnect and lock out power before servicing to prevent unexpected start-up. Failure to do so could result in death or serious injury.



#### NOTICE:

Do NOT override the motor protection repeatedly if it has tripped. Doing so may result in equipment damage.

Cause	Remedy
The motor protection is set too low.	Set the motor protection according to the data plate and if applicable the cable chart.
The impeller is difficult to rotate by hand.	<ul style="list-style-type: none"> <li>Clean the impeller.</li> <li>Clean out the sump.</li> <li>Check that the impeller is properly trimmed.</li> </ul>
The drive unit is not receiving full voltage on all three phases.	<ul style="list-style-type: none"> <li>Check the fuses. Replace fuses that have tripped.</li> <li>If the fuses are intact, then notify a certified electrician.</li> </ul>
The phase currents vary, or they are too high.	Contact a sales or authorized service representative.
The insulation between the phases and ground in the stator is defective.	<ol style="list-style-type: none"> <li>Use an insulation tester. With a 1000 V DC megger, check that the insulation between the phases and between any phase and ground is &gt; 5 megaohms.</li> <li>If the insulation is less, then do the following: Contact a sales or authorized service representative.</li> </ol>

Cause	Remedy
The density of the pumped fluid is too high.	Make sure that the maximum density is 1100 kg/m <sup>3</sup> (9.2 lb/US gal) <ul style="list-style-type: none"> <li>Change the impeller, or</li> <li>Change to a more suitable pump</li> <li>Contact a sales or authorized service representative.</li> </ul>
There is a malfunction in the overload protection.	Replace the overload protection.

If the problem persists, then contact a sales or authorized service representative.

Always state the serial number of the product, see [Product Description](#) on page 5.

## 7.6 The pump delivers too little or no water



### DANGER: Crush Hazard

Moving parts can entangle or crush. Always disconnect and lock out power before servicing to prevent unexpected start-up. Failure to do so could result in death or serious injury.



### NOTICE:

Do NOT override the motor protection repeatedly if it has tripped. Doing so may result in equipment damage.

Cause	Remedy
The impeller rotates in the wrong direction.	<ul style="list-style-type: none"> <li>If it is a 3-phase pump, then transpose two phase leads.</li> <li>If it is a 1-phase pump, then do the following: Contact a sales or authorized service representative.</li> </ul>
One or more of the valves are set in the wrong positions.	<ul style="list-style-type: none"> <li>Reset the valves that are set in the wrong position.</li> <li>Replace the valves, if necessary.</li> <li>Check that all valves are correctly installed according to media flow.</li> <li>Check that all valves open correctly.</li> </ul>
The impeller is difficult to rotate by hand.	<ul style="list-style-type: none"> <li>Clean the impeller.</li> <li>Clean out the sump.</li> <li>Check that the impeller is properly trimmed.</li> </ul>
The pipes are obstructed.	To ensure a free flow, clean out the pipes.
The pipes and joints leak.	Find the leaks and seal them.
There are signs of wear on the impeller, pump, and casing.	Replace the worn parts.
The liquid level is too low.	<ul style="list-style-type: none"> <li>Check that the level sensor is set correctly.</li> <li>Depending on the installation type, add a means for priming the pump, such as a foot valve.</li> </ul>

If the problem persists, then contact a sales or authorized service representative.

Always state the serial number of the product, see [Product Description](#) on page 5.

## 8 Technical Reference



### 8.1 Motor data

Feature	Description
Motor type	Squirrel-cage induction motor
Frequency	50 Hz or 60 Hz
Supply	3-phase
Starting method	Direct on-line or Star-delta
Maximum starts per hour	15 evenly-spaced starts per hour
Code compliance	IEC 60034-1
Voltage variation without overheating	±10%, if it does not run continuously at full load
Voltage imbalance tolerance	2%
Stator insulation class	F (155°C [311°F])

### Motor encapsulation

Motor encapsulation is in accordance with IP68.

### Application limits

Data	Description
Liquid temperature	40°C (104°F) maximum
Liquid density	1100 kg/m <sup>3</sup> (9.2 lb per US gal) maximum
pH of the pumped media (liquid)	5.5-14 for cast iron pumps
Depth of immersion	20 m (65 ft) maximum
Other	For the specific weight, current, voltage, power ratings, and speed of the pump, see the data plate of the pump.



# Xylem |'zīləm|

- 1) The tissue in plants that brings water upward from the roots;
- 2) a leading global water technology company.

We're a global team unified in a common purpose: creating advanced technology solutions to the world's water challenges. Developing new technologies that will improve the way water is used, conserved, and re-used in the future is central to our work. Our products and services move, treat, analyze, monitor and return water to the environment, in public utility, industrial, residential and commercial building services settings. Xylem also provides a leading portfolio of smart metering, network technologies and advanced analytics solutions for water, electric and gas utilities. In more than 150 countries, we have strong, long-standing relationships with customers who know us for our powerful combination of leading product brands and applications expertise with a strong focus on developing comprehensive, sustainable solutions.

For more information on how Xylem can help you, go to [www.xylem.com](http://www.xylem.com)



Xylem Water Solutions Global Services AB  
361 80 Emmaboda  
Sweden  
Tel: +46-471-24 70 00  
Fax: +46-471-24 74 01  
<http://tpi.xyleminc.com>

Visit our Web site for the latest version of this document and more information

The original instruction is in English. All non-English instructions are translations of the original instruction.

© 2014 Xylem Inc